



STATEC BINDER

highly efficient bagging and palletizing solutions

system-R

Form, fill and seal packaging machine

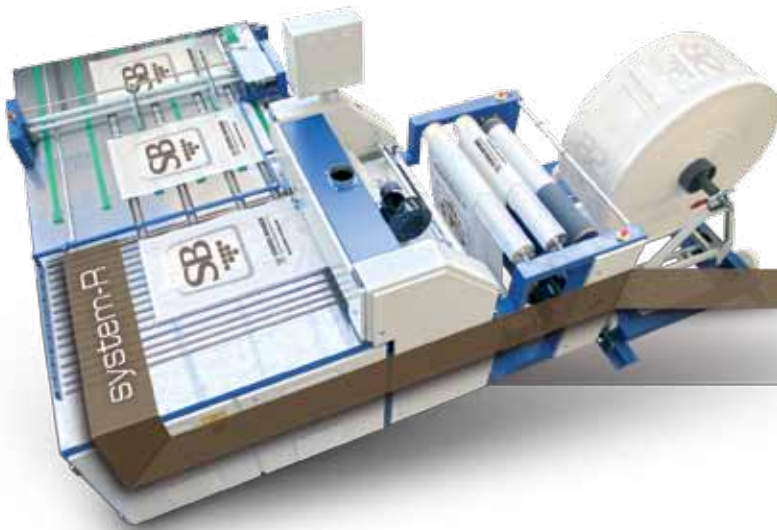

up to

2000

bags per hour



- ✓ Form, fill & seal packaging machine
- ✓ Produces pillow and/or gusseted bags
- ✓ Reduction of bag, personnel and logistic costs up to 50%
- ✓ High productivity and availability
- ✓ CE certified
- ✓ High energy efficiency



The first high-capacity packaging system which combines direct production of bags made of endless tubular woven PP / HDPE cloth with approved STATEC BINDER packaging systems. This achieves significant advantages for your packaging plant!

Concept:

The packaging system is fed by a high capacity bag conversion line. This machine was designed specially for cutting, sewing and handing over of bags made of tubular woven PP or HDPE cloth in an automatic process.

Advantage of System-R:

- Reduction of bag costs up to 50%

- Reduction of personal costs more than 50%
- Decreasing of logistical effort
- High productivity and reliability
- Low bag thickness - high strength
- High availability by applying approved systems

System components:

- Unwinding Unit
- Edge guiding system
- Inline gusseting device (optional)
- Cross cutting device
- Bottom folding device
- High duty bottom stitching machine
- Take over module
- Opening device
- Bag placing system
- Filling spout with integrated spreading device

- Bag transfer to bag closing device

Manner of work:

- The tubular cloth is unwinded from the reel and cut in defined length
- Grippers take the bag and transfer it to the sewing station, where the bag bottom is folded and stitched
- The finished bag is handed over to the packaging system and transported to the opening table
- There the bag will be opened and placed on the filling spout
- Filling through swivel spout
- Spreading of bag mouth through integrated spreading device
- Releasing of bags and bag closing
- Transfer to the downstream logistic

All movements and functions are controlled by a free programmable PLC



STATEC BINDER

highly efficient bagging and palletizing solutions

system-R

Form, fill and seal packaging machine

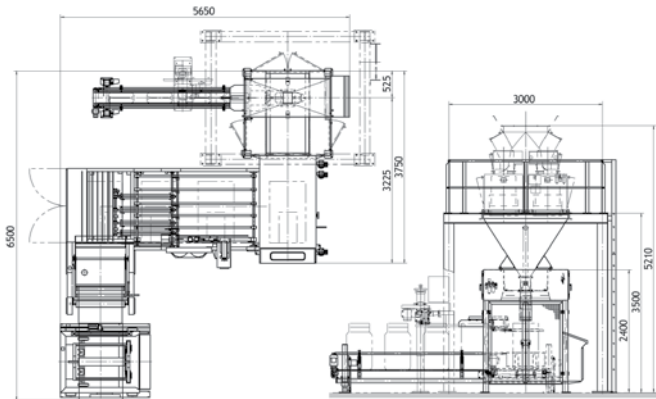

STATEC BINDER System-R

Filling system:	certopac / principac
Design capacity:	up to 33 bags/min.
Packaging capacity:	up to 2000 bags/h
Bag making capacity:	up to 2200 bags/h
Filling weight:	5 - 50 kg
Bag material:	Woven PP / HDPE (coated / uncoated)
Bag types:	gusseted bag / pillow bag
Weight of empty bag:	80 - 120 g/m ²
Bag length:	500 - 1200 mm
Width of tubular cloth:	270 - 700 mm
Max. diameter of reel:	1500 mm
Bags per reel:	approx. 6.000 pcs
Power consumption:	approx. 10 kW
Air consumption:	approx. 30 m ³ /h